

Brightlands Symposium:
Circular Challenges of Plastics Packaging
17-09-2020

Chemische en fysische recycling, nu en toekomst
Mark Roelands – TNO / mark.roelands@tno.nl



Contents

Chemical and Physical Recycling

1. Recycling packaging plastics - introduction
2. Physical recycling (dissolution of polymers)
- *TNO Moebius dissolution technology*
3. Chemical recycling (depolymerization to monomers)
4. Thermo-chemical recycling (conversion to feedstock)
- *TNO thermal cracking technology*

EU plastic waste - sources

Production Europe: 56M Ton
Demand: 49 million tonnes

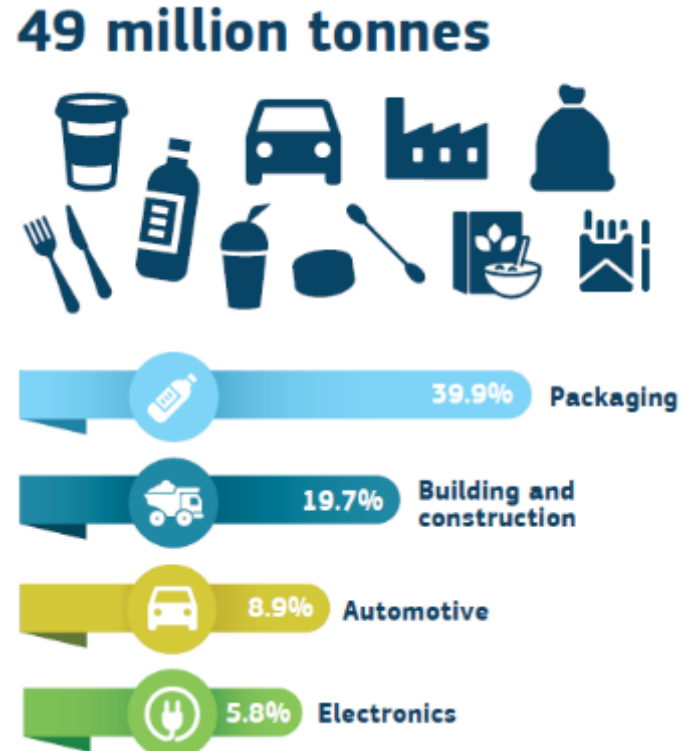

EU PLASTIC WASTE GENERATION IN 2015

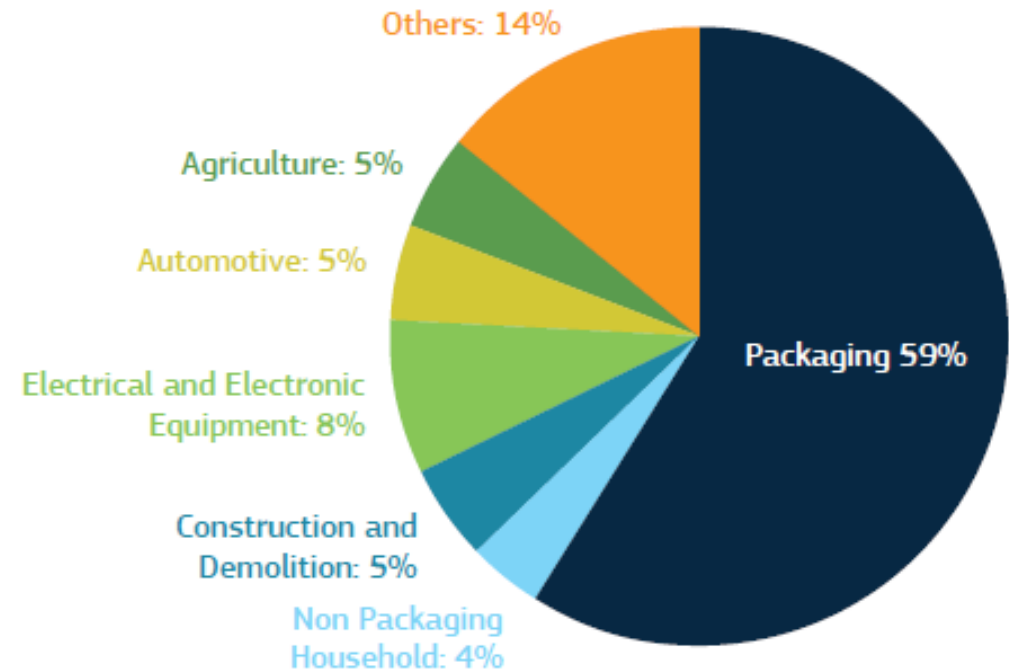

Source: Plastic Europe 2016 and Eunomia 2017

There is global momentum for a circular redesign of the plastics value chain

Circular Plastics Alliance

- EU initiative
- 10 MT recycled plastics into new products 2025



Alliance to End Plastic Waste

- \$1.5 Billion investment
- 30+ Global Brands



CEFLEX

European Consortium of producers, converters, brand owners and recyclers



New Plastics Economy

Signatories:

- 350+ Global Commitment
- 250+ Plastics Pact

Dutch and European Plastic Pacts

Rethink Plastic

- Leading European NGOs
- Redesign, reduction & recycling

PCEP

PlasticsEurope, European Plastics Converters and Plastics Recyclers Europe



Materials Systemic Transition from linear to circular chain driven by consumer product companies feeling pressure from concerned citizens

Actual: linear chain for plastics is dominant with large CO₂ emission and little circularity

2. Industries feeling pressure to change to circularity

1. Environmental issues causing concern to users

3. Industries facing major transition

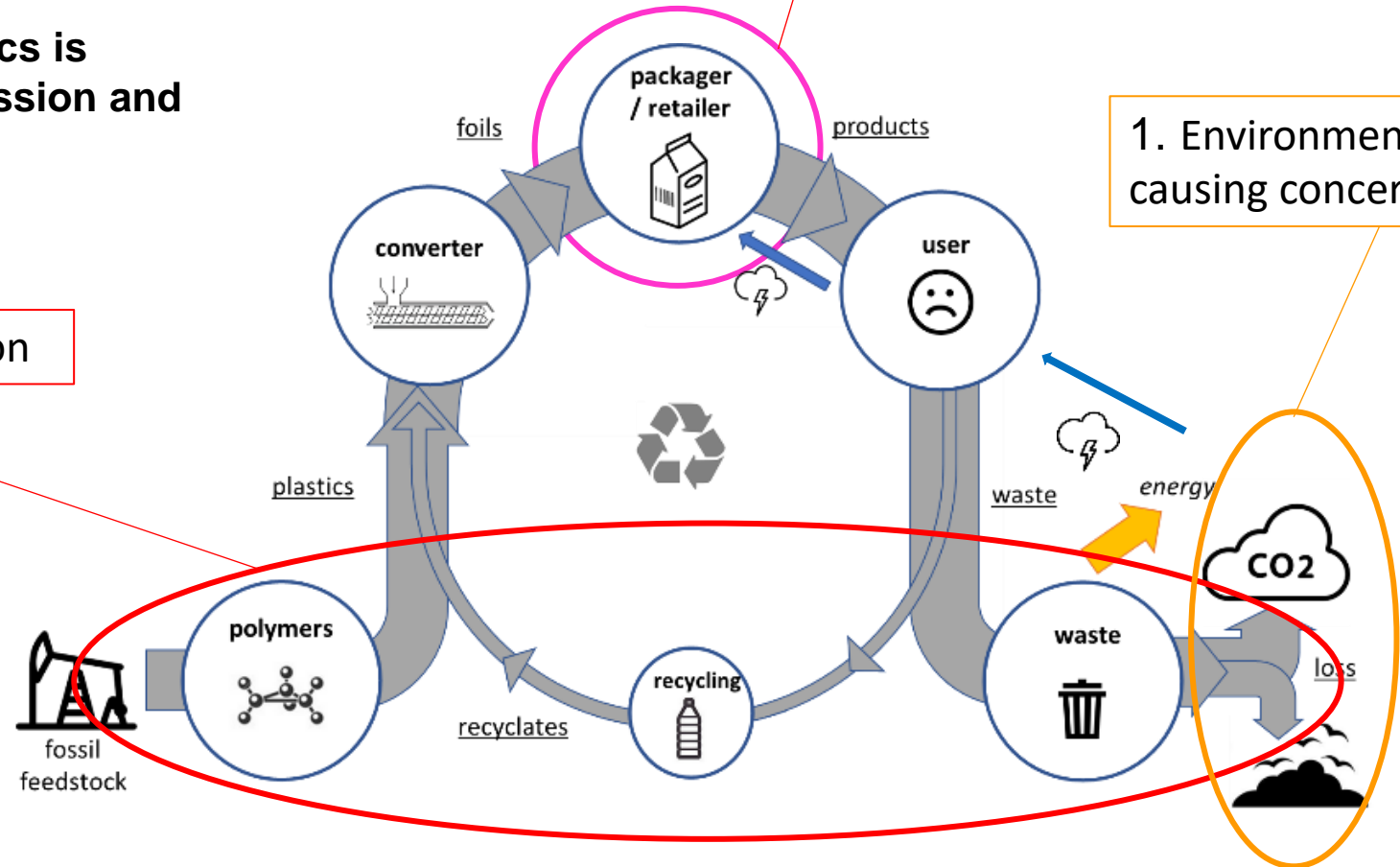

Materials Systemic Transition from linear to circular chain leads to major transition of industries for polymers, recycling & waste

Vision: full circular chain for plastics with suppletion by renewable feedstock for complete defossilization

3. Industries facing major transition

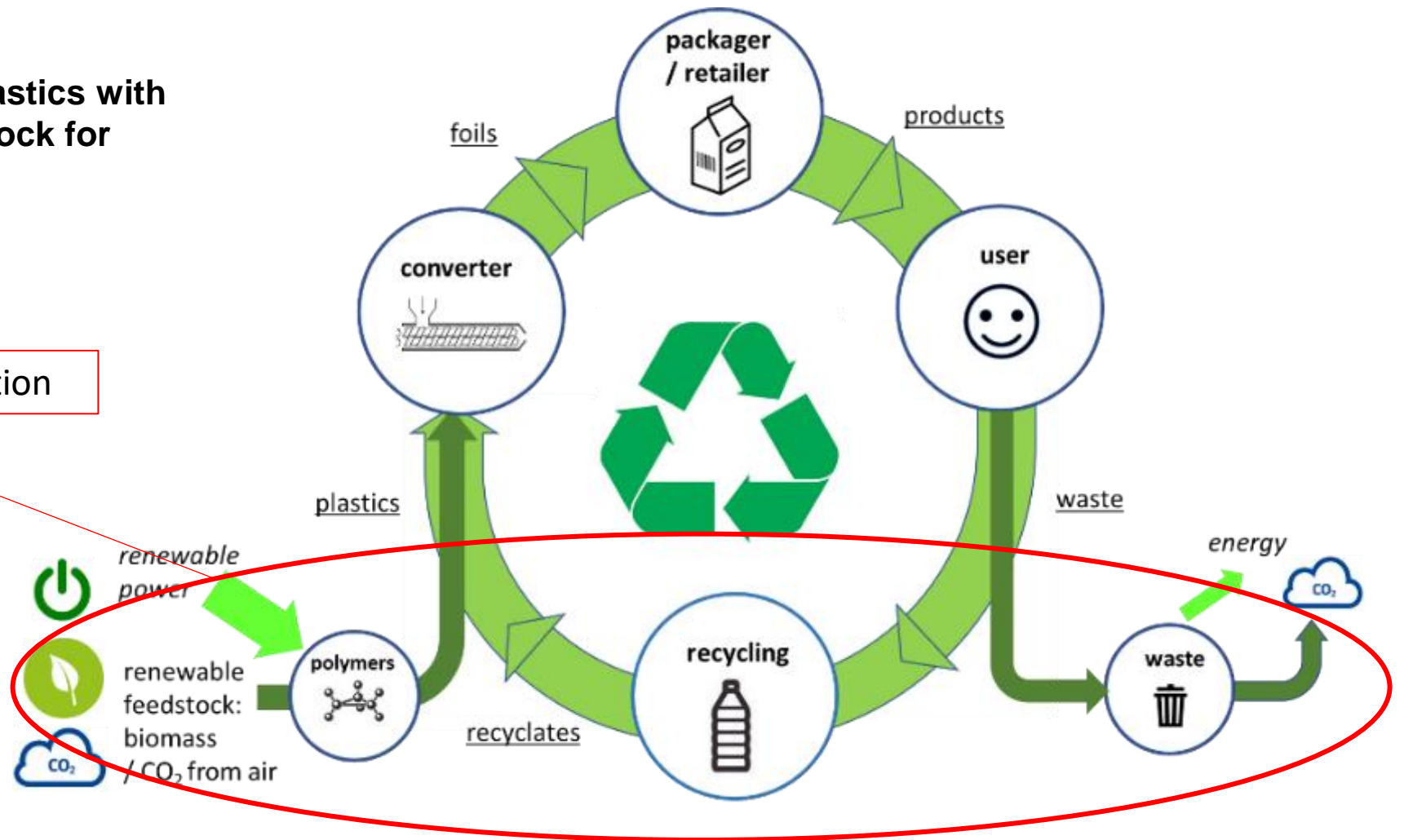

Circular plastics in the value chain

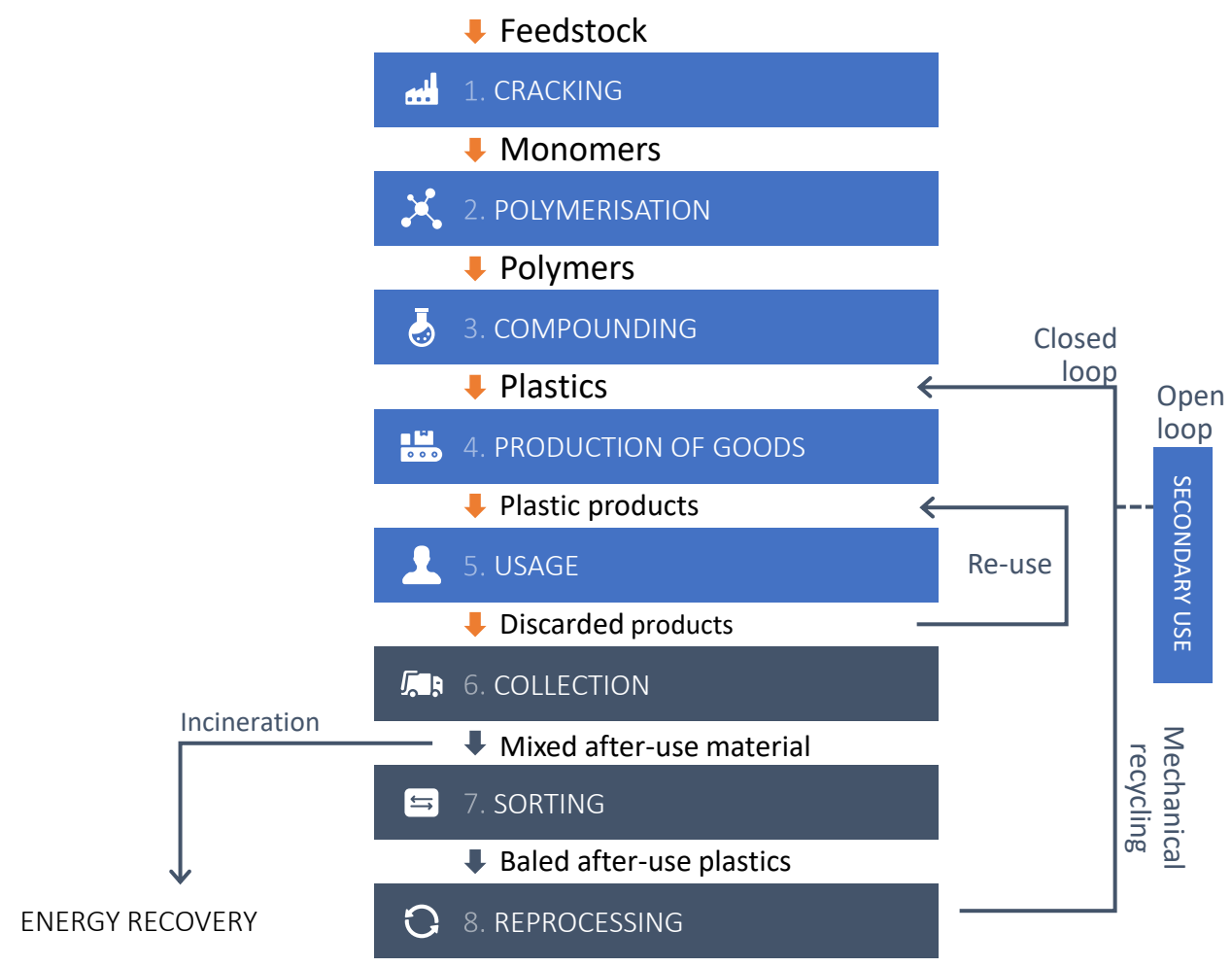

Sorting and mechanical recycling

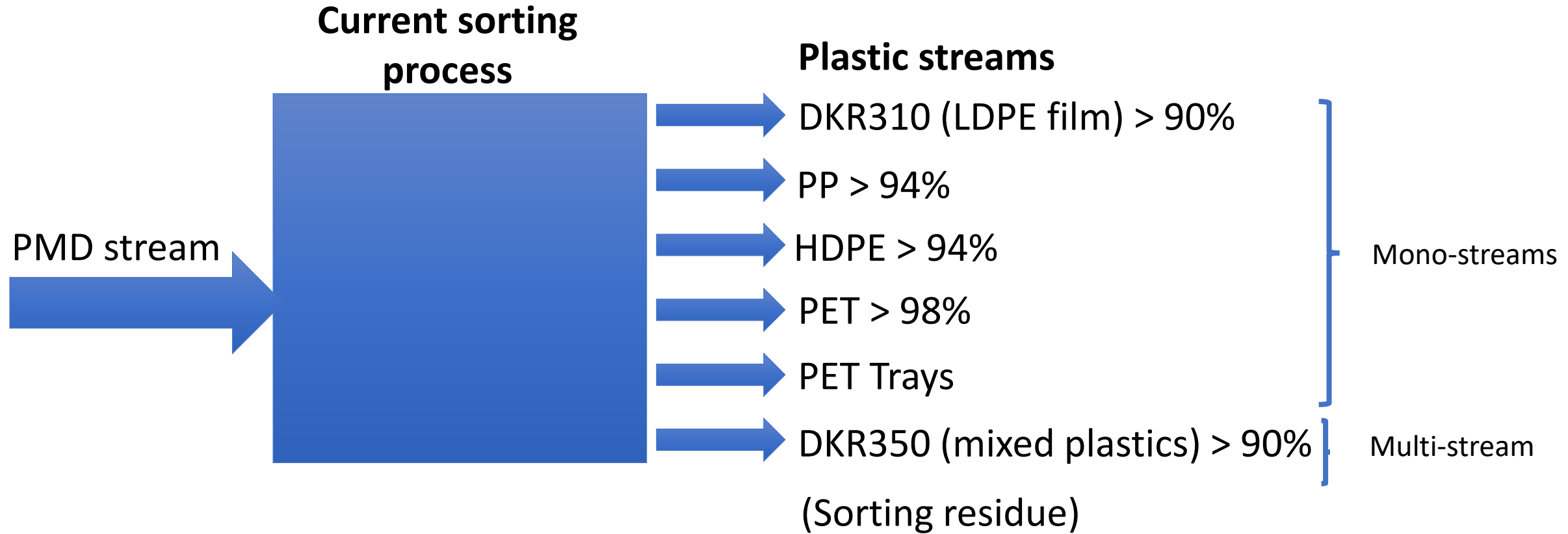

=> Objective : more plastics recycled and higher quality

Circular plastics in the value chain

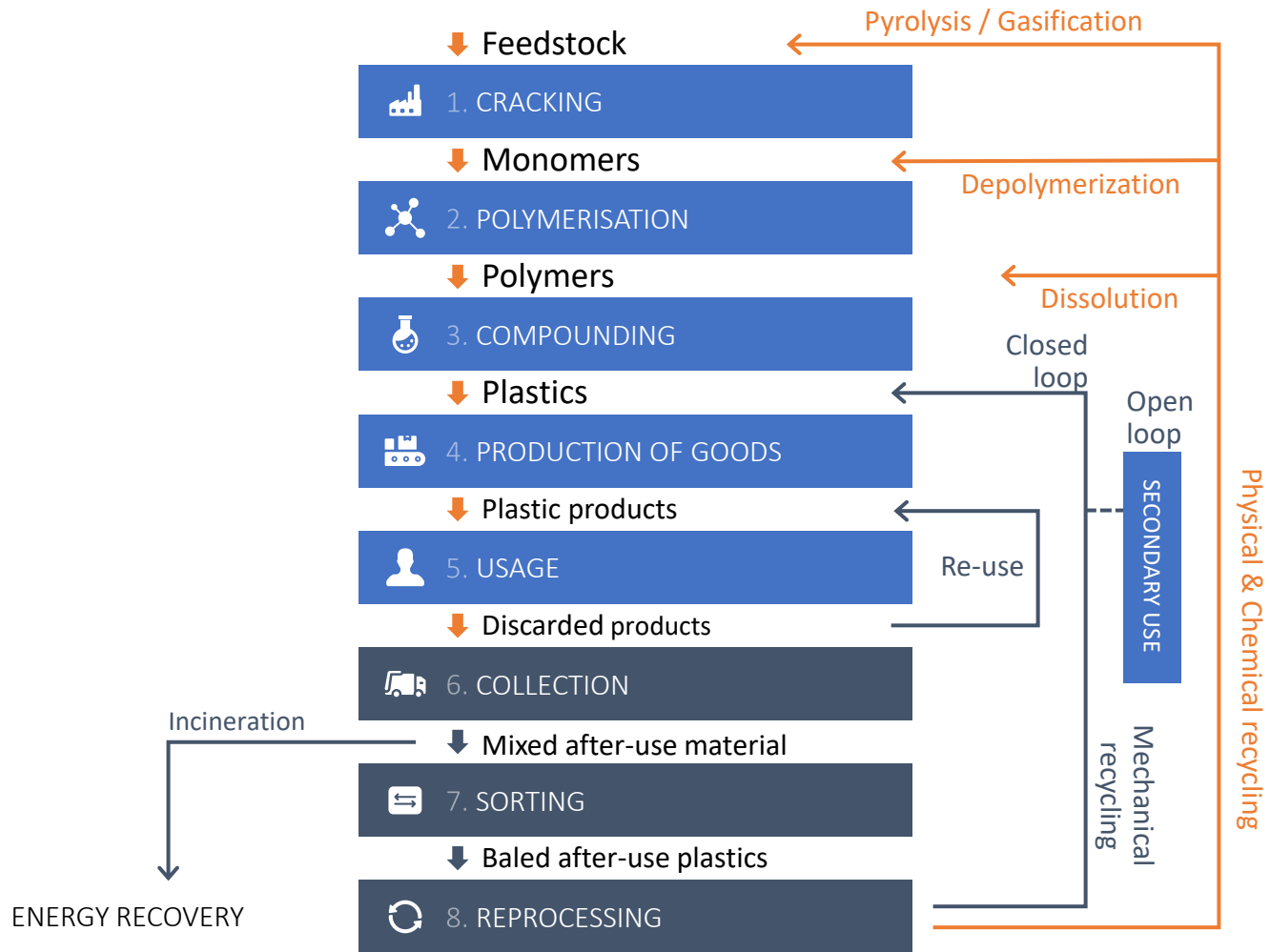

Beyond Mechanical Recycling: Giving New Life to Plastic Waste

Ina Vollmer, Michael J. F. Jenks, Mark C. P. Roelands, Robin J. White, Toon van Harmelen, Paul de Wild, Gerard P. van der Laan, Florian Meirer, Jos T. F. Keurentjes, and Bert M. Weckhuysen*

Keywords:
catalysis · chemical recycling · circularity · plastic waste · solvolysis



Angewandte
International Edition
Chemie

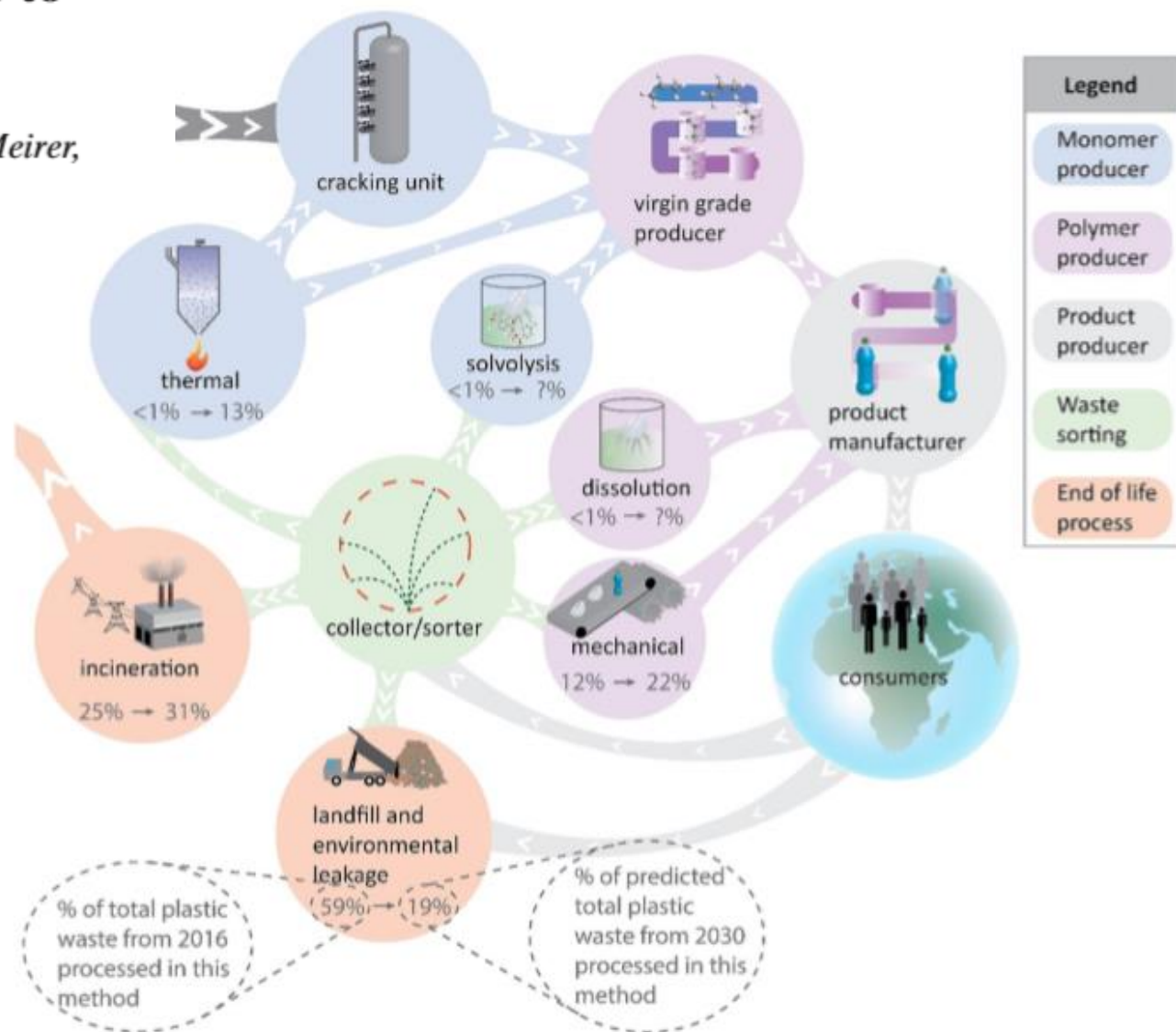

Circular plastics in the value chain

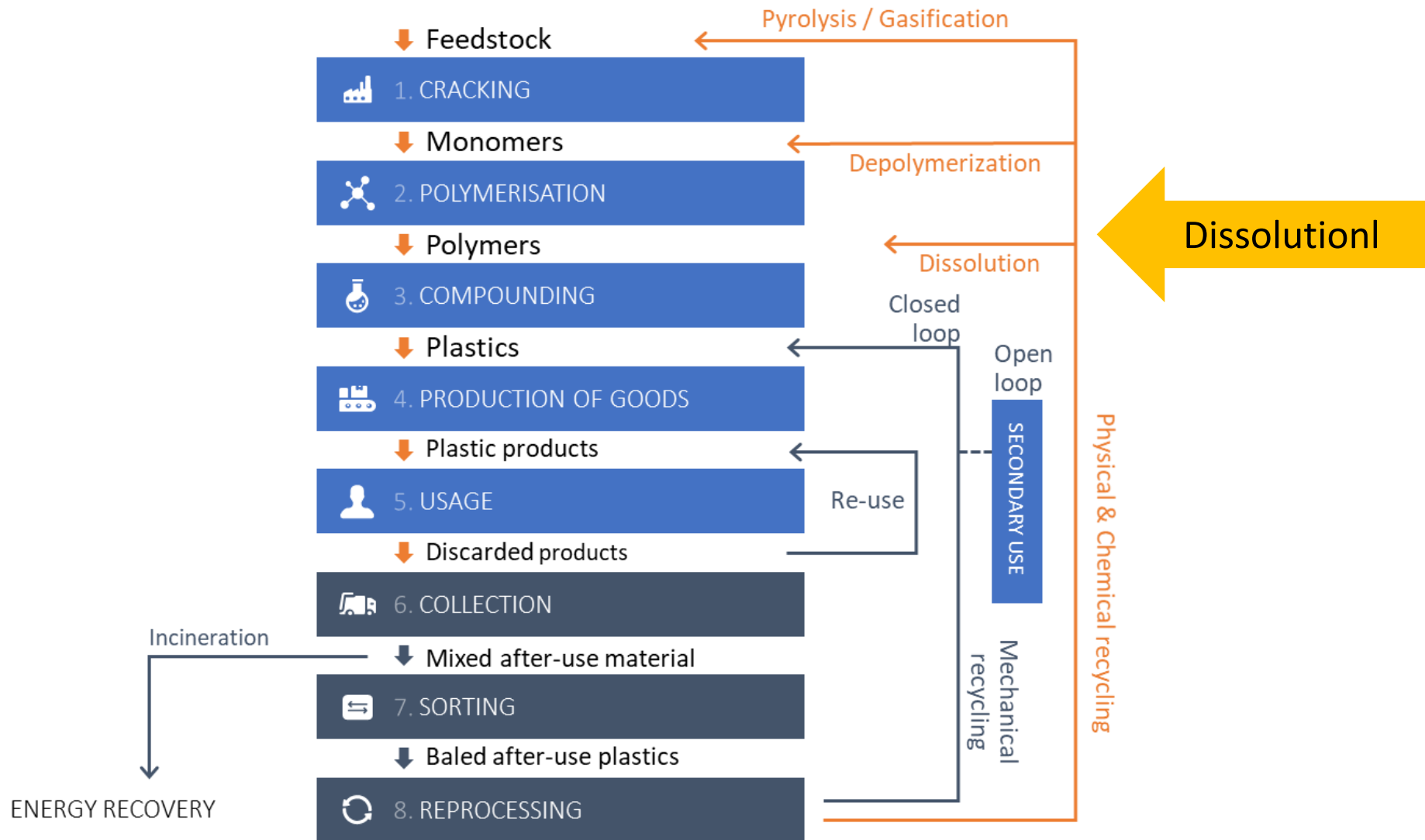

Dissolution - state of the art

APK Newcycling process

- Polyethylene (PE) and polyamid-6 (PA6) recovery from waste plastics
- Partnership with Henkel/Mondi
- Partnership with DSM on PE-PA multilayers



Source: APK Newcycling website

Dissolution - state of the art

CreaSolv - Unilever (Indonesia)

- Polyolefin recovery from waste plastics
- CreaSolv technology (Fraunhofer IVV)
- 30 tpd capacity

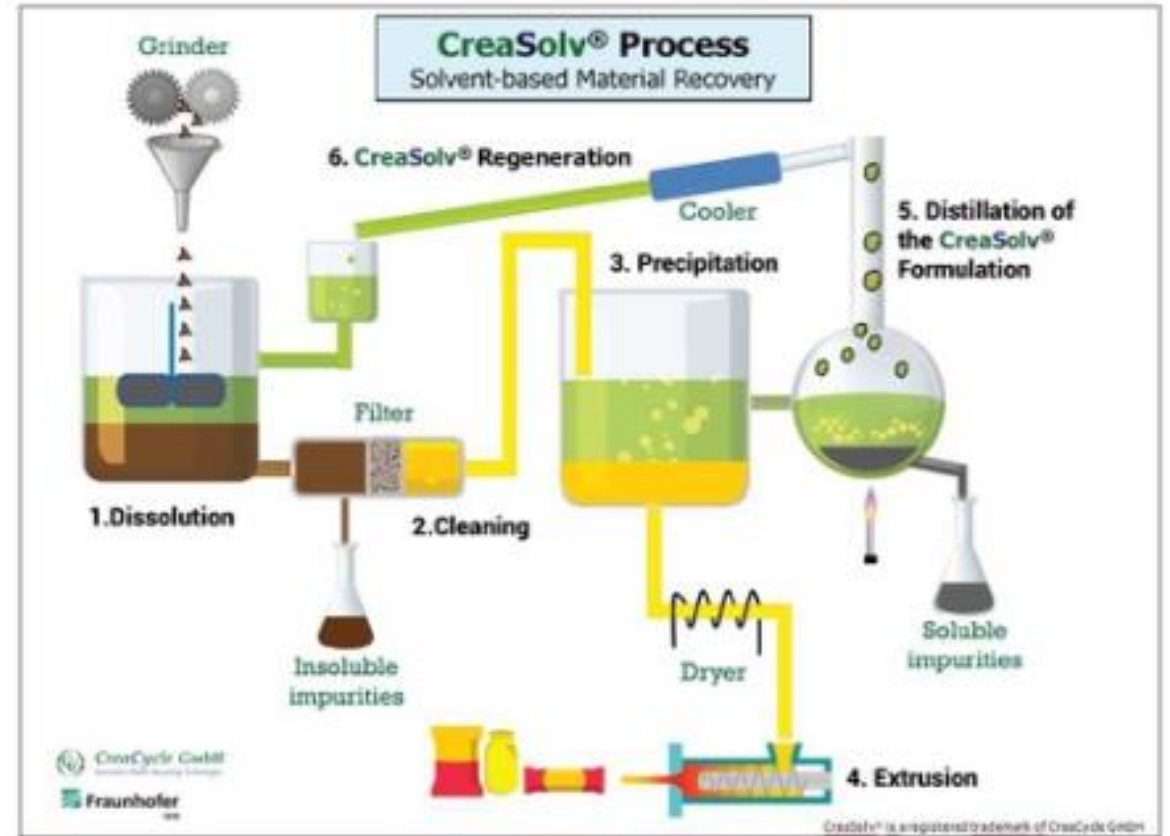

Source: CreaSolv

Dissolution - state of the art PureCycle (P&G)

- Polypropylene recovery from waste plastics
- Supercritical butane technology



PureCycle Technologies and P&G introduce technology that enables recycled plastic to be nearly-new quality



Source: PureCycle website

Dissolution - state of the art Polystyvert

Polystyvert
Recyclage de polystyrène

- Polystyrene recovery from waste ePS packaging
- Dissolution in p-cymene
- Recovery of polystyrene



Source: Polystyvert website



15

Dissolution - state of the art

Obbotec (Netherlands)

- Polyolefin recovery from waste plastics
- PlantOne Rotterdam

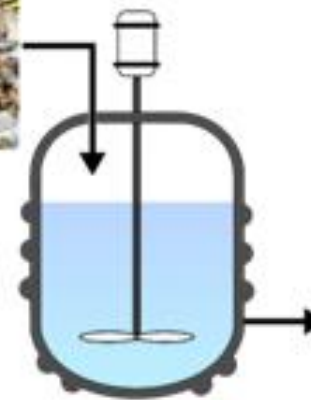

Was stap

PE, PP



- Zware metalen (Cd, etc...)
- Additieven (weekmakers, brandvertragers, etc.)

Solvent recycling

Source: Obbotec website

OBBOTEC

Dissolution - state of the art PolystyreneLoop

CreaSolve technology (Fraunhofer IVV)
EPS recycling – removal flame retardant
3 kta demo

EPS CreaSolv® Recycling Demo Plant

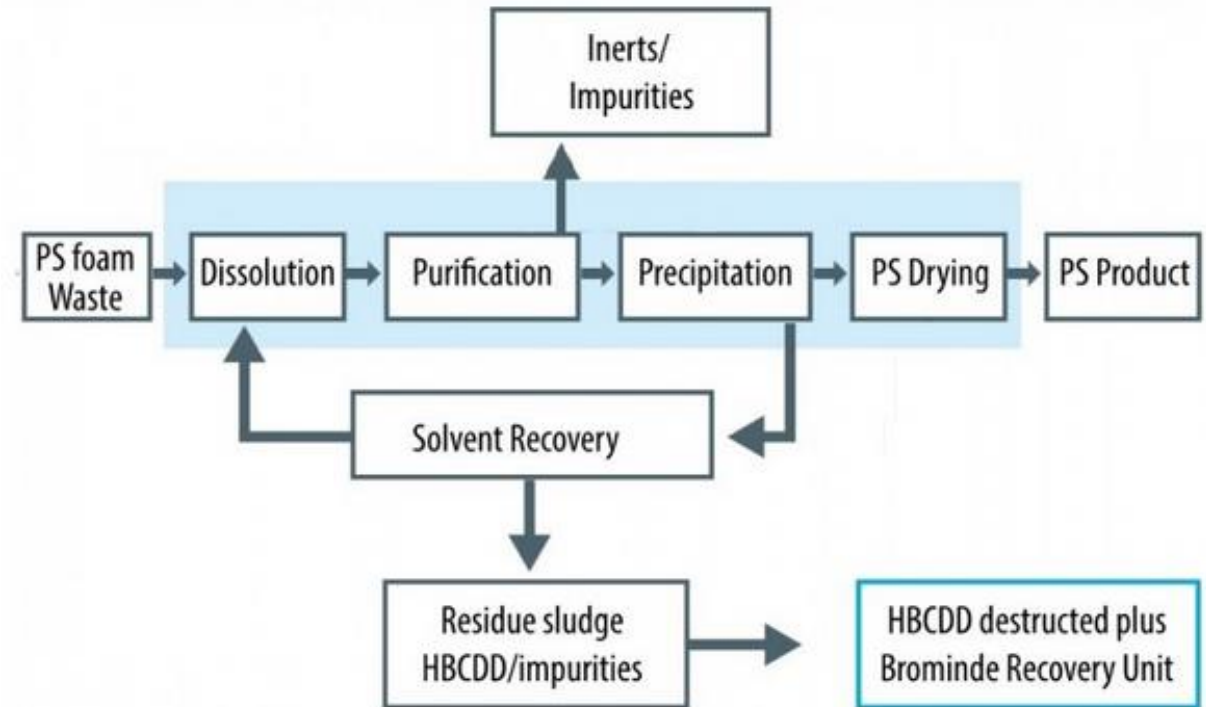
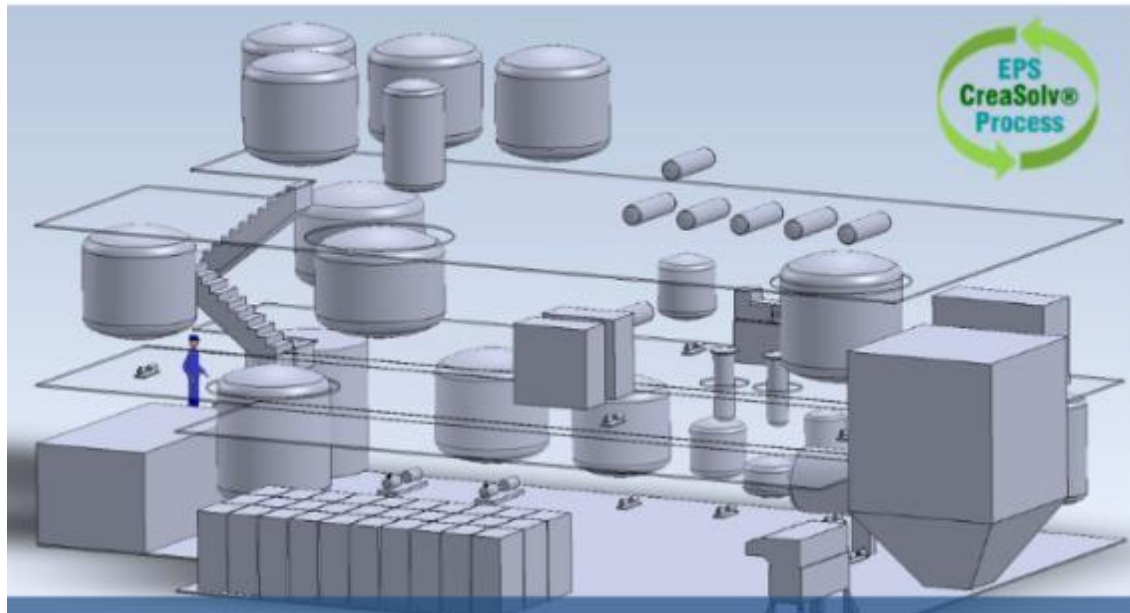

Construction started
Terneuzen (NL)

Dissolution – TNO Möbius concept

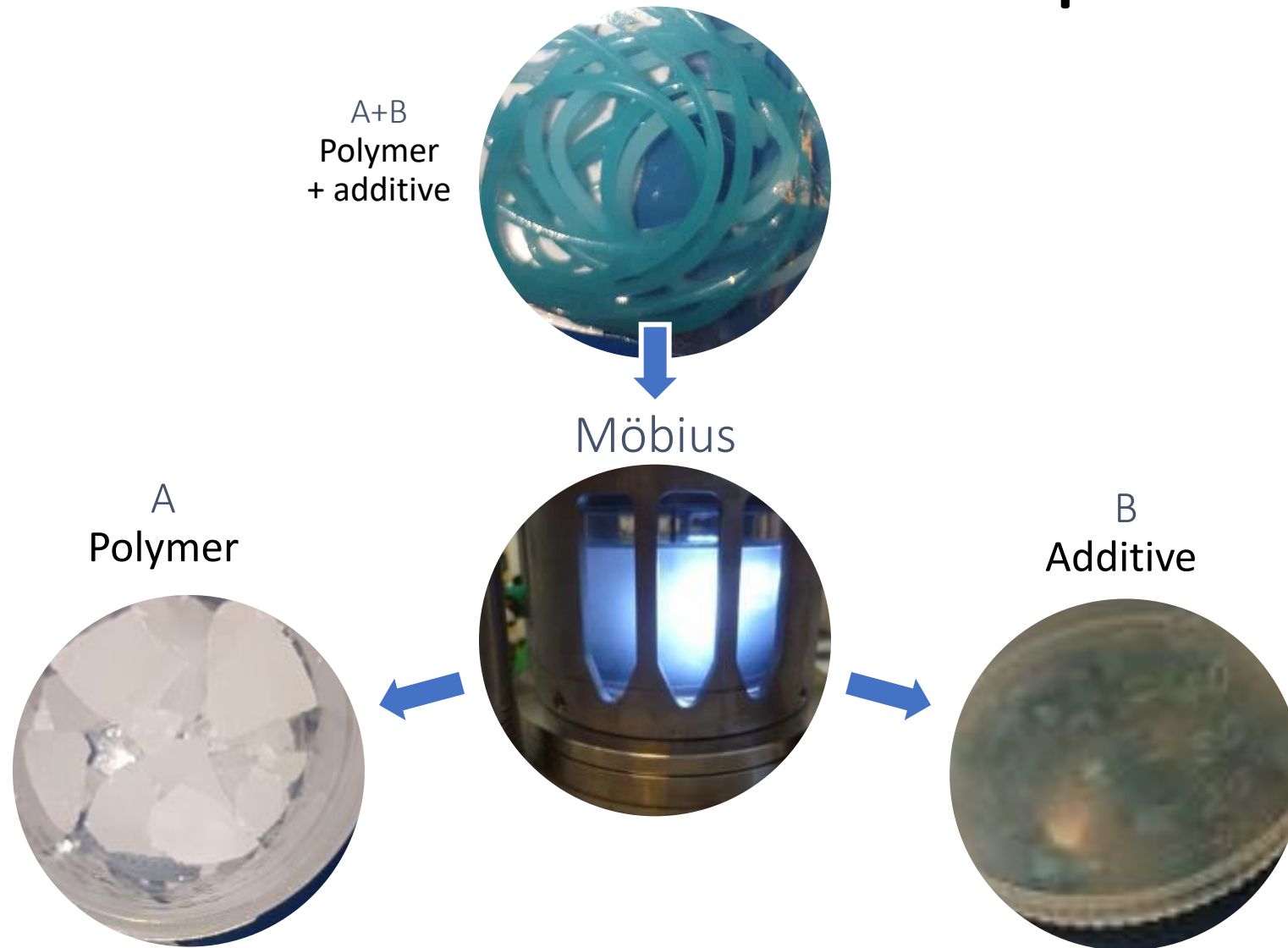

Diss



waste
plastic

process
polymer



Dissolution - Möbius Applications

- Focus on two types of plastic waste :

a. **multilayer polyolefin films** (non-durable < 1 yr)

=> recovery of polyolefins, separation from other materials



MUCIPACK



b. **multimaterial engineering plastics** (durable > 1 yr)

=> recovery of polymers, removal of additives

- WEEE plastics
- EoL vehicles
- carpets / sports turf
- toys / furniture

PL^oST2b
CLEANED



SORTYFLOOR



› Dissolution - Möbius roadmap

› Möbius0.01

Batch
TRL 2

2018



1g
Dissolution

› Möbius0.1

Batch
TRL 2-3

2018



10g
Dissolution
Separation
(Polymer recovery)

› Möbius1.0

Semi-Batch
TRL 4

2019



100g
Dissolution
Separation
Polymer recovery
Solvent recovery

› Möbius2.0

Semi-continuous
TRL 5-6

2022

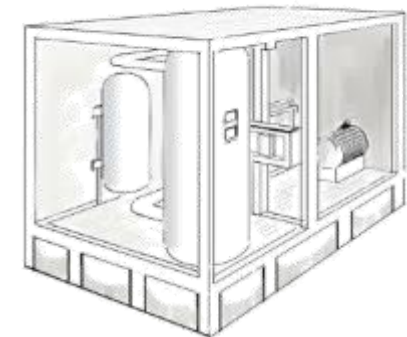

1000 g
Dissolution
Separation
Polymer recovery
Solvent recycle

Dissolution – Recyclable Multilayer Packaging consortium PACK-CE



Dissolution - experimental results – 2-layer

Liter scale experiments:

- Laminate 2-layers PET/PP
- Solvent selective to dissolve CPP
- Starting material separated in PP and PET fractions with 90% efficiency
- FTIR analysis confirms recovery of pure PP; PU adhesive at residual PET strips
- Printing ink remains on PET

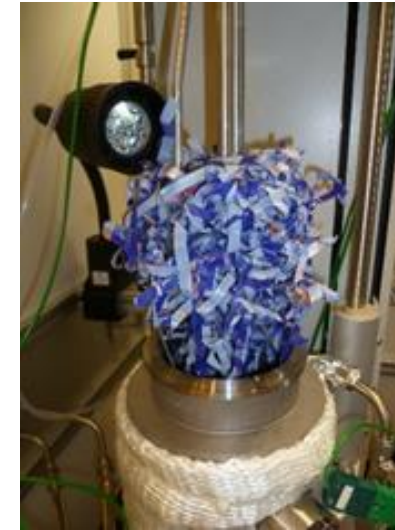

Residual strips: PET



Product: PP fraction

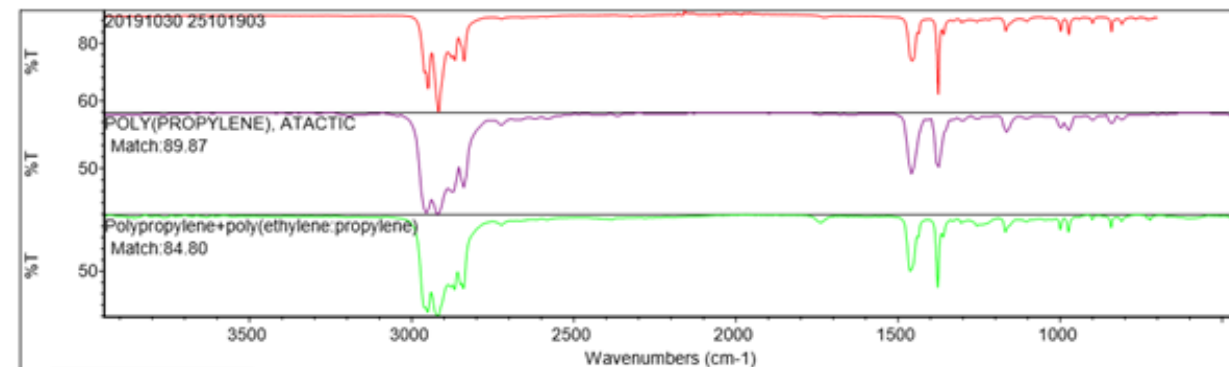

Dissolution - experimental results – 3-layer

Liter scale experiments:

- Laminate 3-layers 20 μ m OPP / 15 μ m BOPA / 35 μ m LDPE
- Solvent selected to dissolve PE and PP fraction
- 70% recovery efficiency
- FTIR analysis still indicates some PE on the residual PA strips; product is pure mixed PP and PE fraction



Starting material



Residual strips



PP and PE fraction

Circular plastics in the value chain

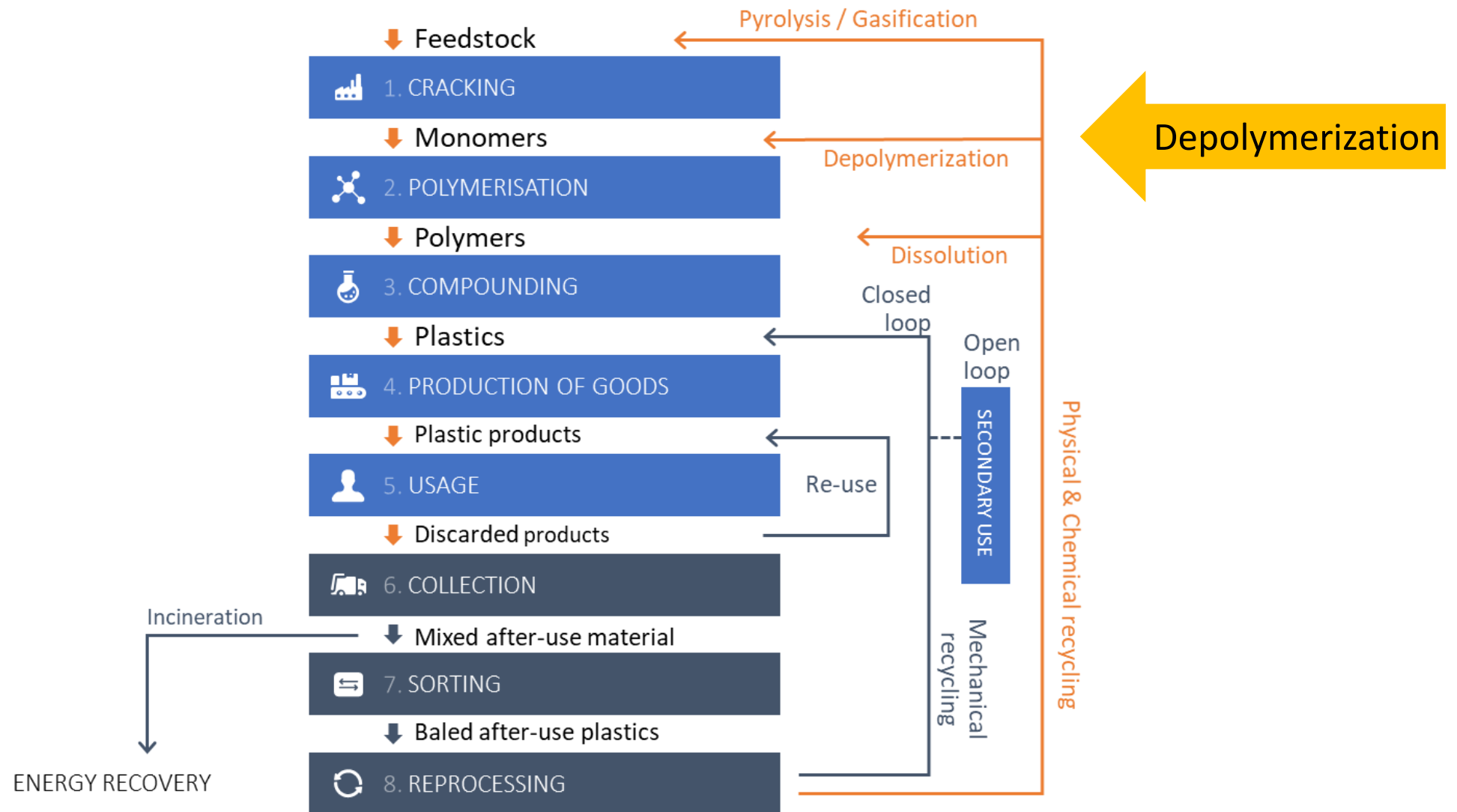

Depolymerization - state of the art

Recycling of purified PET monomers

Coloured PET depolymerization to monomers – for repolymerization:

1. Hydrolysis – with water

- Carbios (enzymatic), Rittec, MISTRA, Gr3n (microwave), BP Infinia

2. Glycolysis – with MEG

- Ioniqa (catalyst on magnetic carrier), CuRe (oligomers), PerPETual (oligomers), DupontTeijin/Poseidon (CRLux), Garbo, Axens, IBM

²⁶ 3. Methanolysis with methanol
- Loop Industries (Suez), Eastman

Depolymerization - state of the art

PET recycling by glycolysis - IONIQA

PET polymers to BHET monomer
Demo plant 10 kta - Geleen (NL)



27



Depolymerization - state of the art

PET recycling by depolymerization - CuRe

- PET to purified oligimers
- Pilot plant Emmen (NL)
- Coca-Cola invests



28

Source: Cumapol website

Depolymerization - state of the art PA-6 recycling by depolymerization to caprolactam - Aquafil

- Aquafil
- Capacity 40 kta (Slovenia)
- Intake fishing nets, carpet fiber



29

Source: Aquafil website

Depolymerization - state of the art polystyrene recycling by depolymerization to styrene monomer - Agilyx

- Agilyx with Ineos Styrolution and TechnipFMC
- Yield on SM approx. 70%

agilyx



30

Source: Agilyx website



Circular plastics in the value chain

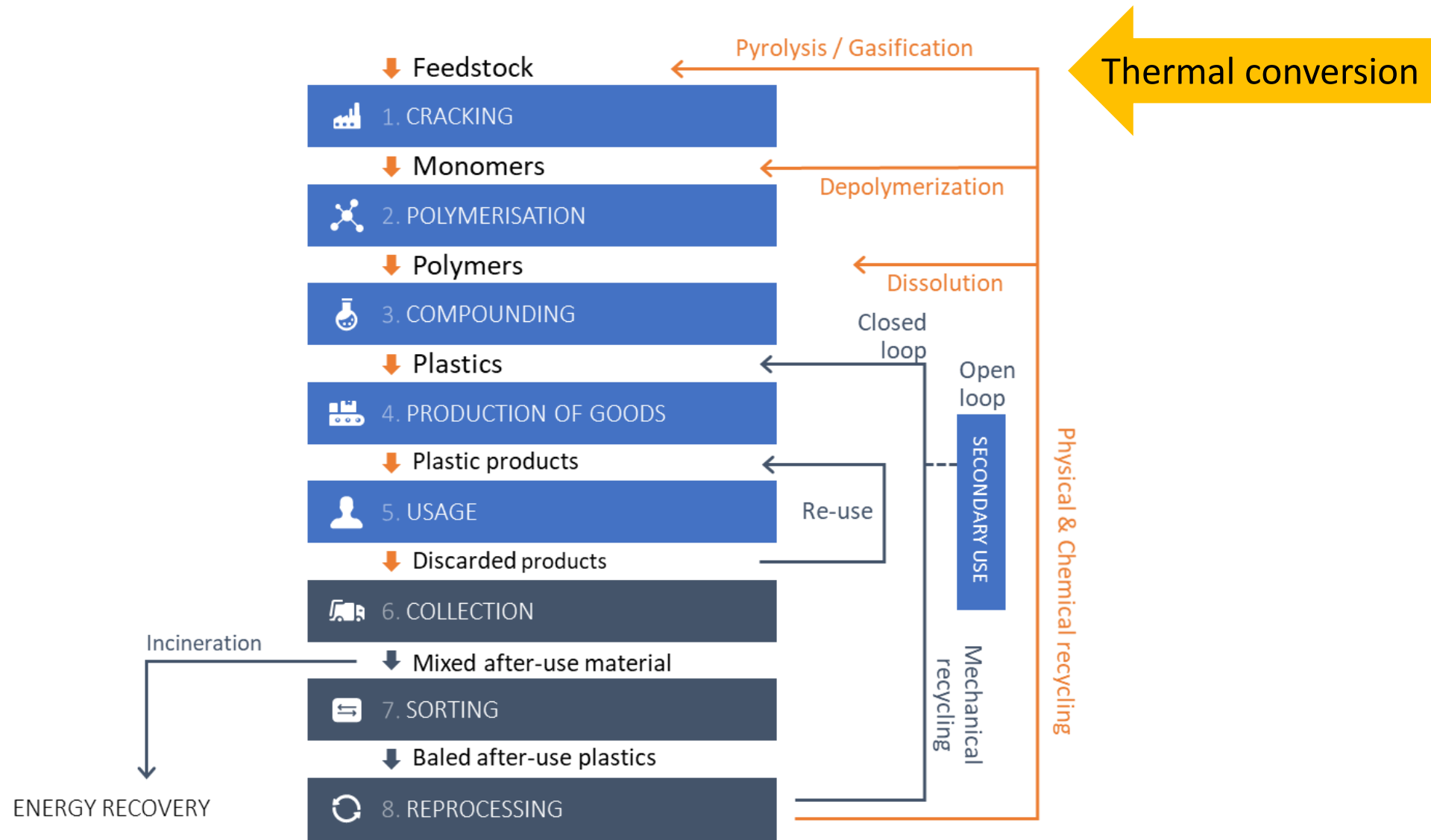

Thermal recycling – Pyrolysis / Gasification



olefins to fractu
eos

htha - to cracker:



POSITION PAPER

March 2020

Introducing chemical recycling: Plastic waste becoming a resource

“Every year, Europeans generate 25 million tonnes of plastic waste, but less than 30% is collected for recycling” states the 2018 European Plastics Strategy.



Chemical Recycling Won't Solve The Plastic Crisis As Over 50% Of Carbon Contained Gets Lost



Emanuela Barbiroglio Senior Contributor @ Energy
I write about sustainability and EU's environmental policies

Chemical recycling: distraction, not solution?

According to GAIA, the industry is using the term “chemical recycling” to greenwash plastic to-fuel technologies, seeking public approval for the continued use and disposal of plastic.



ais:

CHEMISCHES KUNSTSTOFFRECYCLING – POTENZIALE UND ENTWICKLUNGSPERSPEKTIVEN

Ein Beitrag zur Defossilisierung der chemischen und kunststoffverarbeitenden Industrie in NRW

Diskussionspapier der Arbeitsgruppe Circular Economy

pyrolysis
sis

B. Gasification: conversion of plastic containing waste with

- Enerkem (Canada) - W2C (Rotterdam) - methanol
- EBARA (Japan) – hydrogen for ammonia(+ fuel gas)



Thermal recycling - Pyrolysis

Plastic Energy = partner with Sabic



Source: Plastic Energy website

Thermal recycling - Pyrolysis

Fuenix- partner with Dow



Source: PlasmaPower / Fuenix website

Thermal recycling - Pyrolysis

Recycling Technologies (UK) process

Pilot on Brightlands

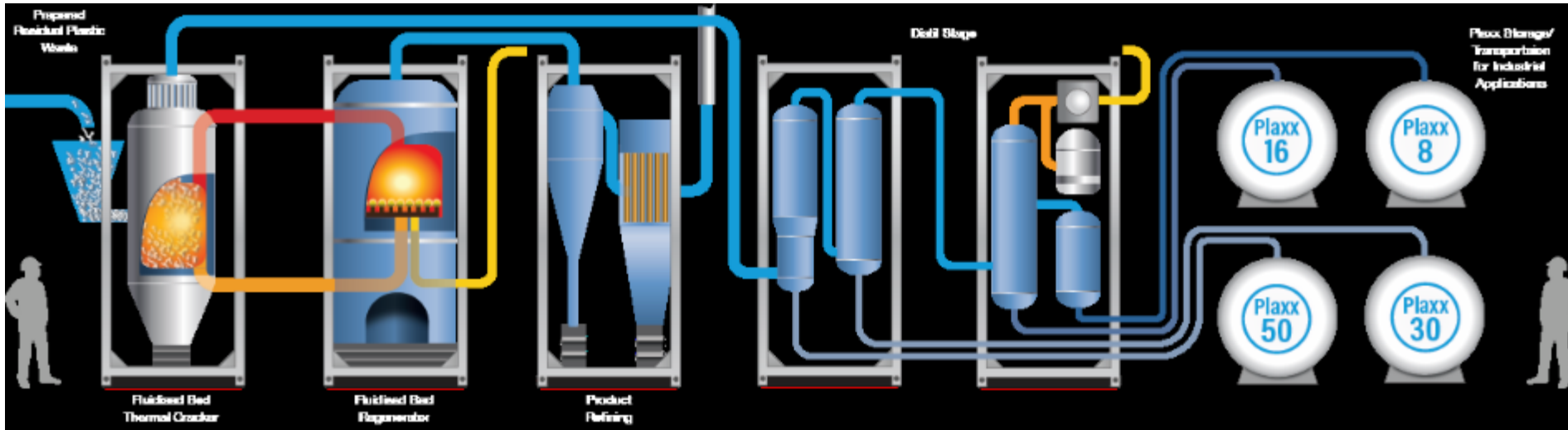

TNO Thermal cracking

› Combination of pyrolysis and cracking in 1 operation



End-of-life
Plastics



~ 3 kg/h



Milena Lab-scale

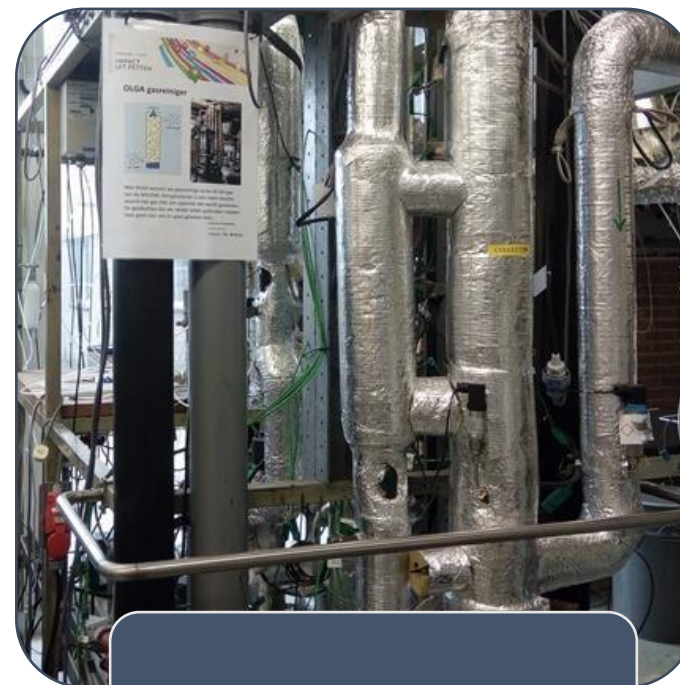

Olga Tar Removal



Olefins
Benzene
fuel gas

Thermal cracking - Experimental set-up

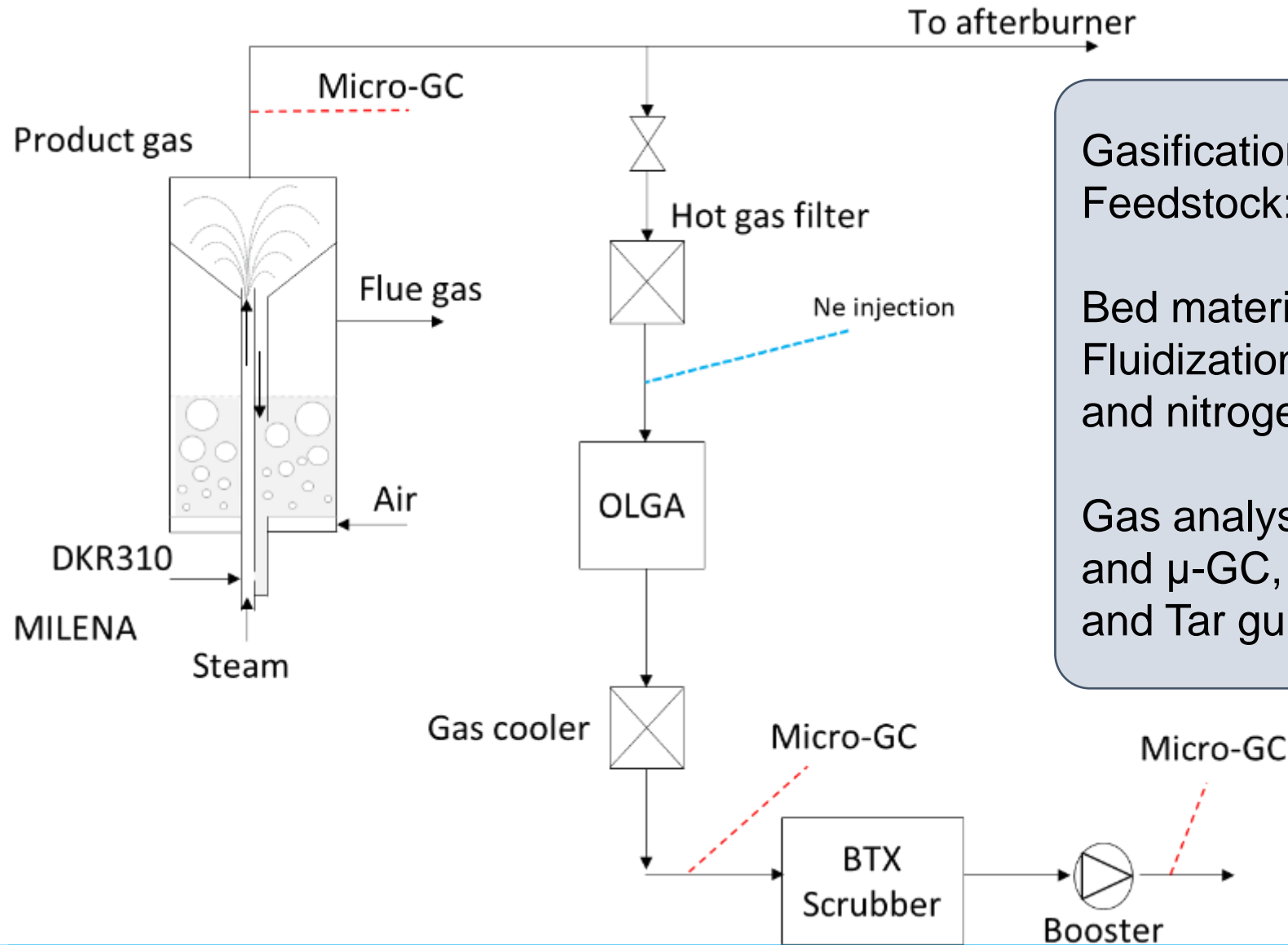

Gasification temperature: **730 °C**
Feedstock: 2.3 kg/h

Bed material: Sand
Fluidization agent: steam (0.8 kg/h) and nitrogen

Gas analysis: online gas analysers and μ -GC, offline GC-FID for HCs and Tar guideline

Thermal cracking - Pre-processing

- Feedstock had to be pre-processed before being fed into the Milena gasifier

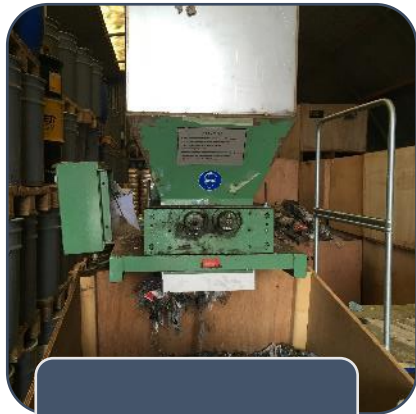

Shredded



Pelletized



Milled



Thermal cracking - Gas Composition after Milena

N_2 also used as fluidizing agent due to hydrodynamics (≈ 45 Vol%)

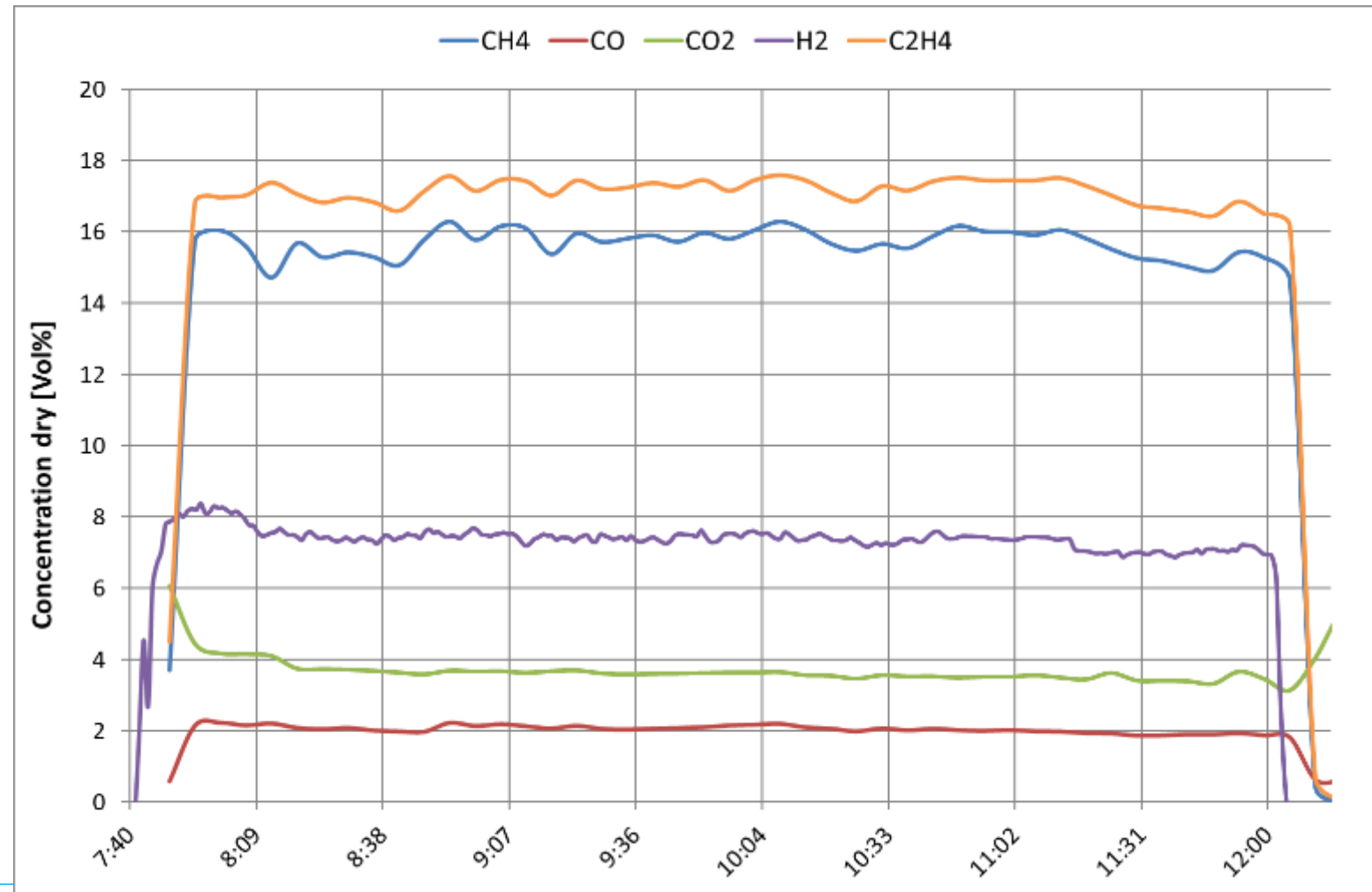

Thermal cracking - Product Gas Composition

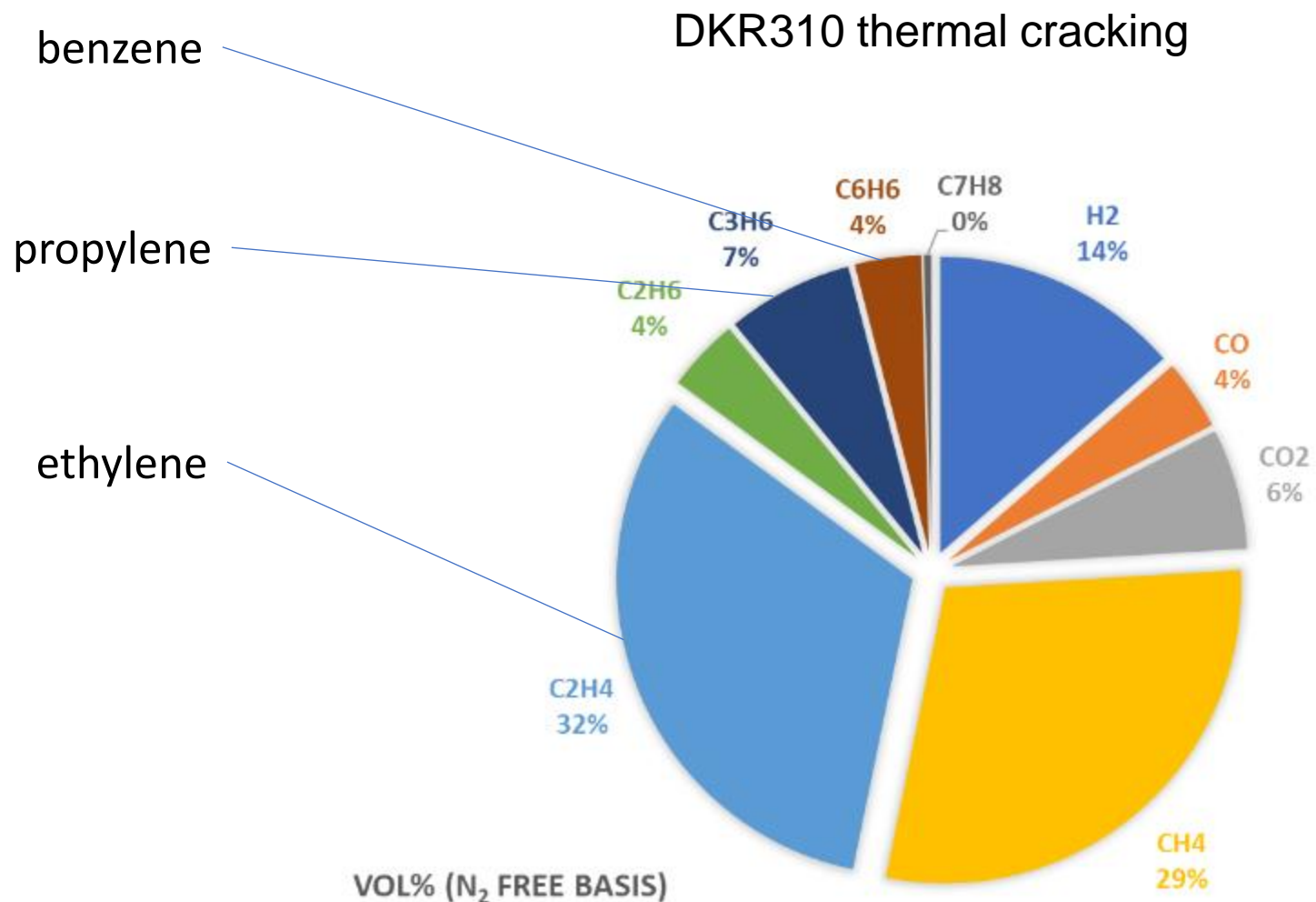

Thermal cracking - Tar guideline



After Milena gasifier



After Olga Tar removal

Thermal recycling – gasification - Enerkem



Waste processing plant (Edmonton)

Waste2Chemical project Rotterdam - planned 360 kta MSW to 220 kta MeOH

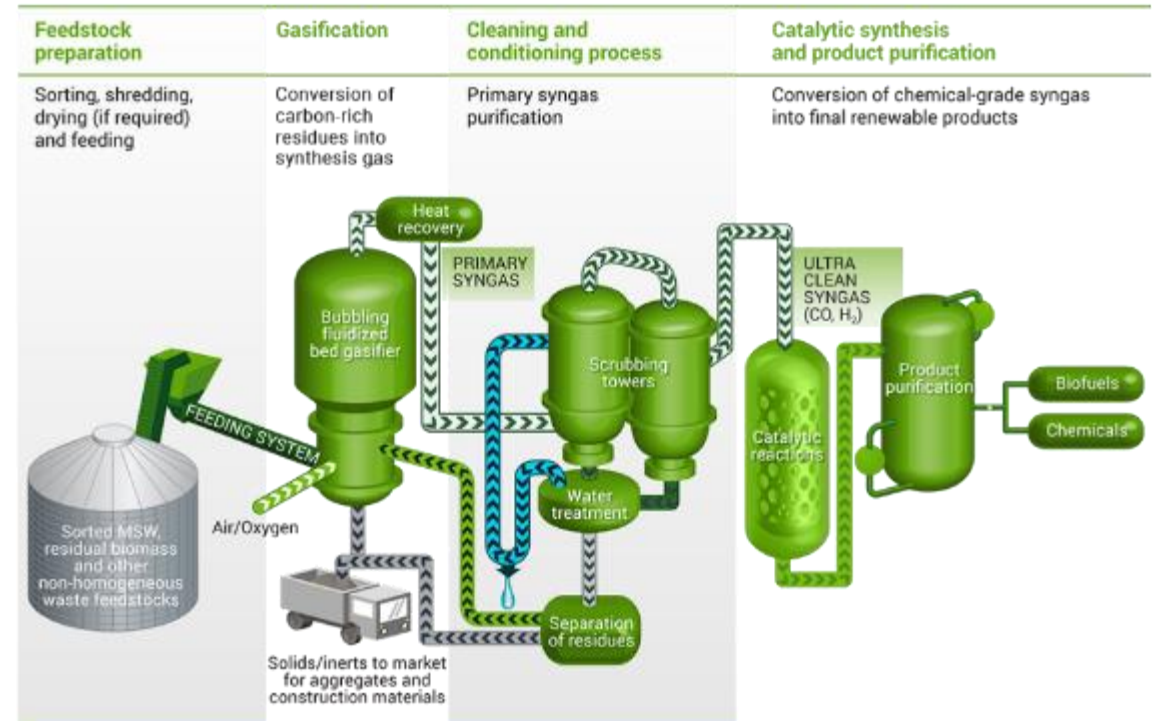

* Municipal solid waste

Source: Enerkem website

Thermal recycling – gasification - EBARA

EBARA process

Produces hydrogen for ammonia plant + fuel gas

Capacity 50 kta (est)

Since 2002

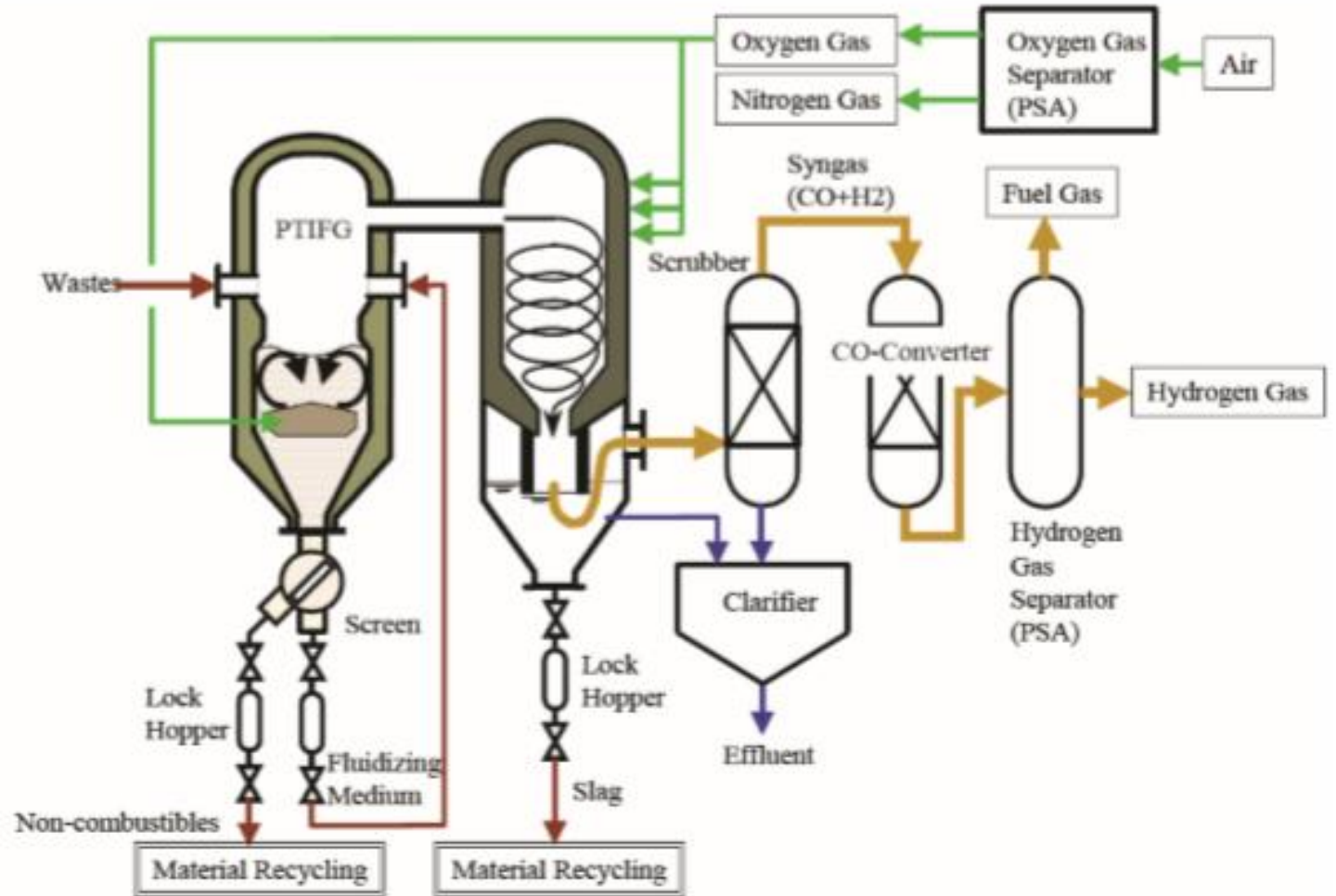

43



EBARA ENVIRONMENTAL PLANT CO., LTD.

Figure 4.23: Ebara EUP process with gas cleaning for ammonia synthesis, [20]

Source: Ebara website

Thermal recycling – plasma arc gasification - AlterNRG

- Plastics multistream as feed
- Capacity 50-80 kta
- Syngas production (=CO/H₂)

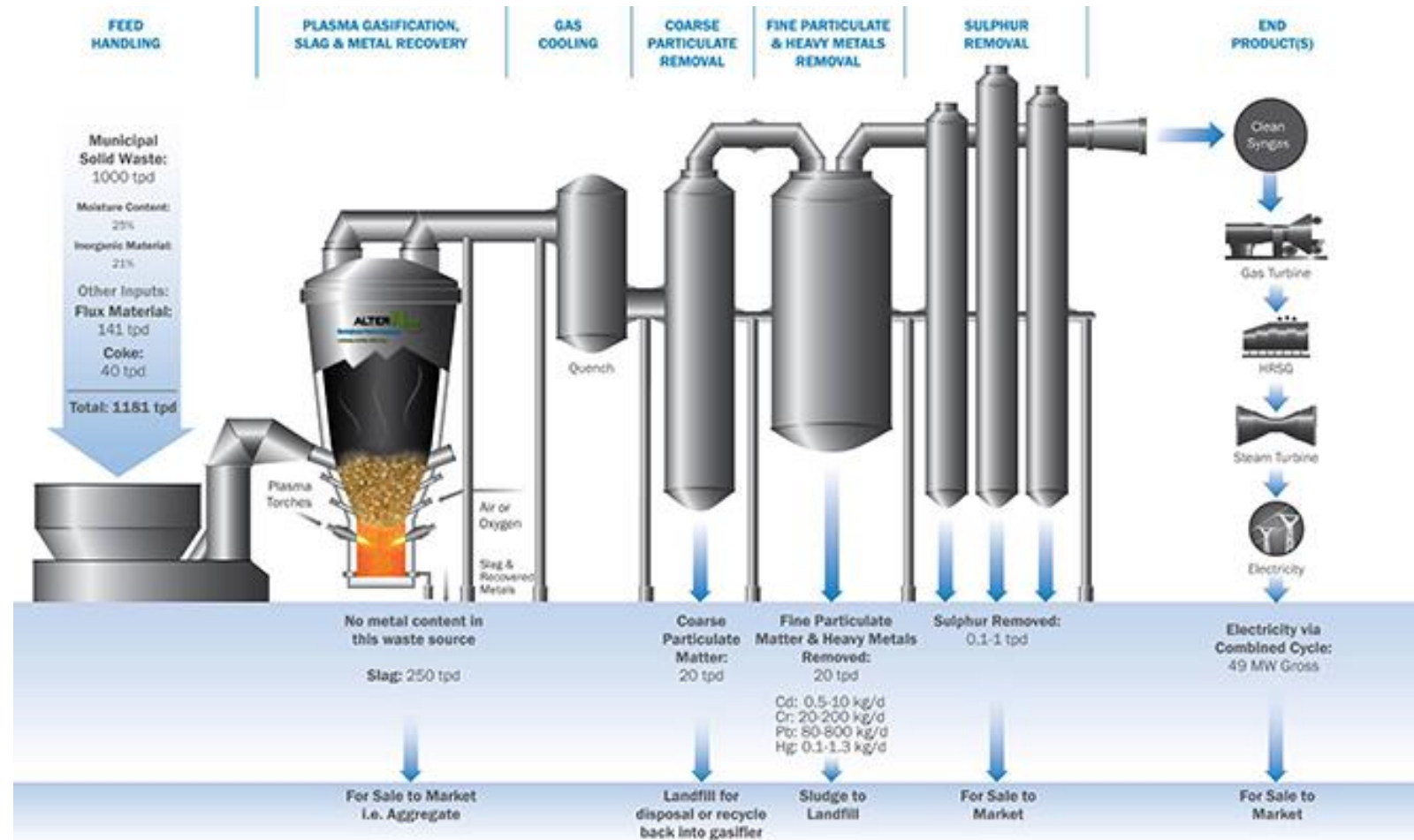

Circular plastics in the value chain

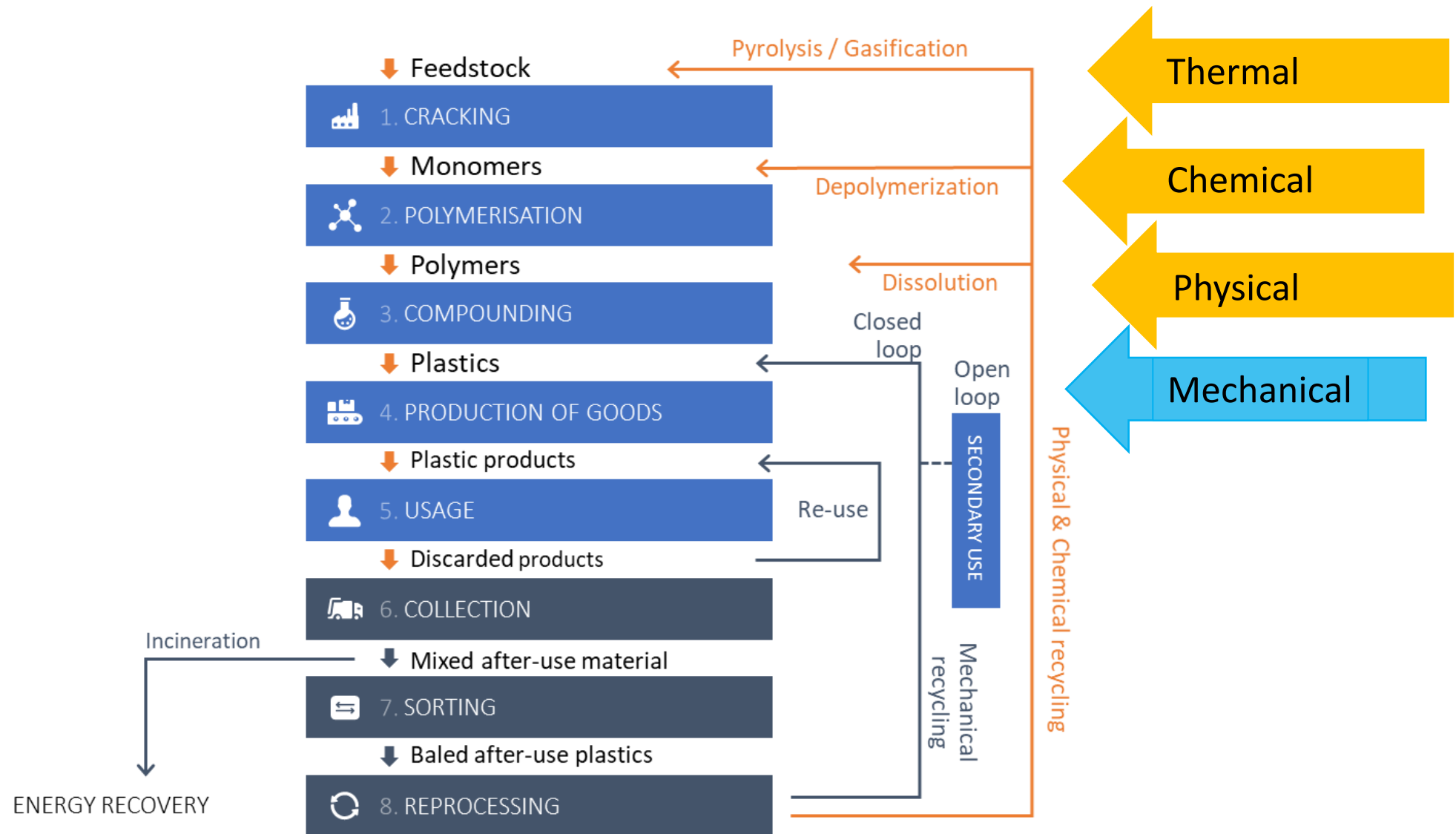

Our Vision

How to achieve Circular Packaging

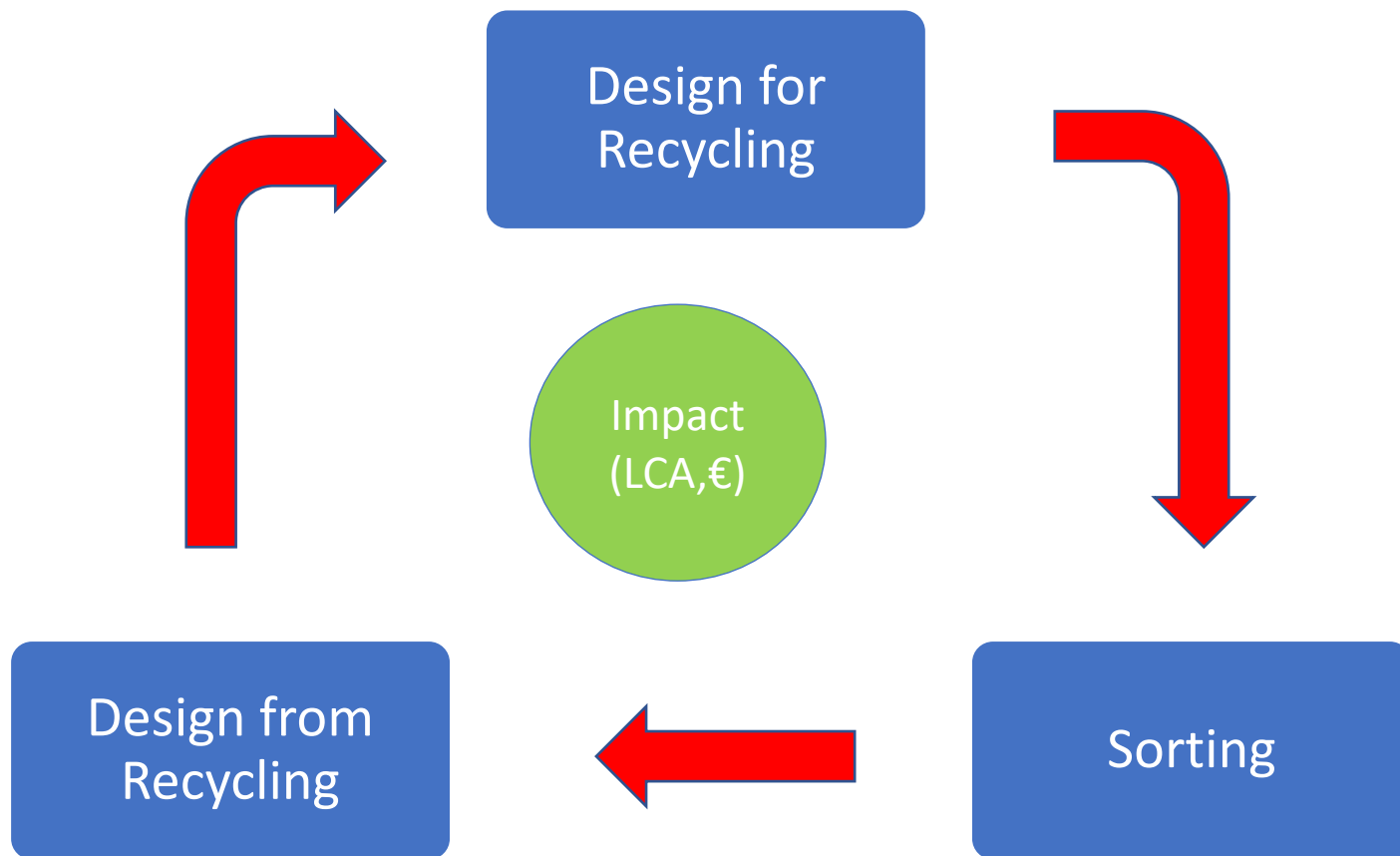

BRIGHTLANDS SYMPOSIUM

Circular Challenges of Plastics Packaging



Knowledge crossing borders

Program:

Tijd	Spreker	Bedrijf	Titel
13:00	Marnix van Gorp	Brightlands Materials Center	Welkom en introductie op het thema
13:15	Caroli Buitenhuis	Green Serendipity	Global, EU en Nederlands beleid op gebied van circulair verpakken
13:40	Luuk Beenders	Blomix	Circulair verpakking ontwerpen
14:05	Vincent Mooij	SUEZ	Circular design is key for recycling
14:30	Tom Ligthart	TNO	LCA's in verpakkingen
14:55	Mark Roelands	TNO	Chemische recycling
15:20			End



› Thank you for your attention
MARK.ROELANDS@TNO.NL